



# 628 New Dundee Rd., Kitchener

Vanessa Hicks, MHBC

January 9, 2024

# Requested for Feedback on Development Proposal in Sept 2023

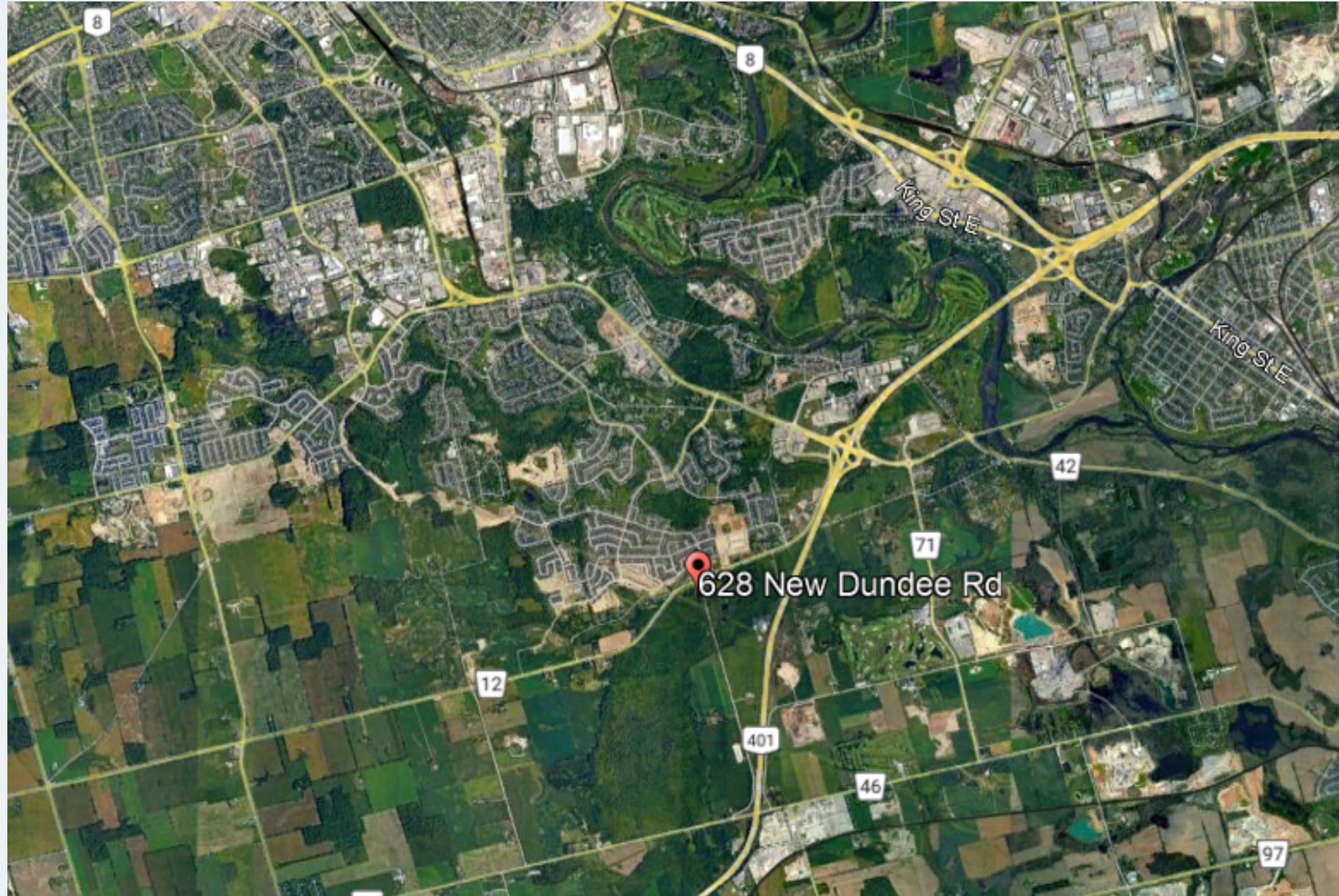

Subject property is located north of New Dundee Road

# Heritage Status & Heritage Permit Application

- Designated under Part IV OHA;
- Designation applies to the whole property;
- Heritage attributes only conserve the original portion of the existing dwelling.



# Proposed Development: Relocation & Conservation



- Retain the existing dwelling and re-locate it within the development proposal for residential use;
- Removal of other features located on-site.

# Proposed Development: Relocation & Conservation

Short Term: prior to re-location

- Remove contemporary additions;
- Remediate any condition issues;
- Building stabilized;
- Prepare for re-location; and
- Site grading & build new foundation.

Medium term: construction phase

- Building re-location;
- Repairs (including masonry);



A second HPA will be required in the future as it relates to other alterations to the building (i.e. new windows, doors, etc.)

Long term: Post construction phase & maintenance/monitoring

# On-site Commemoration Strategy

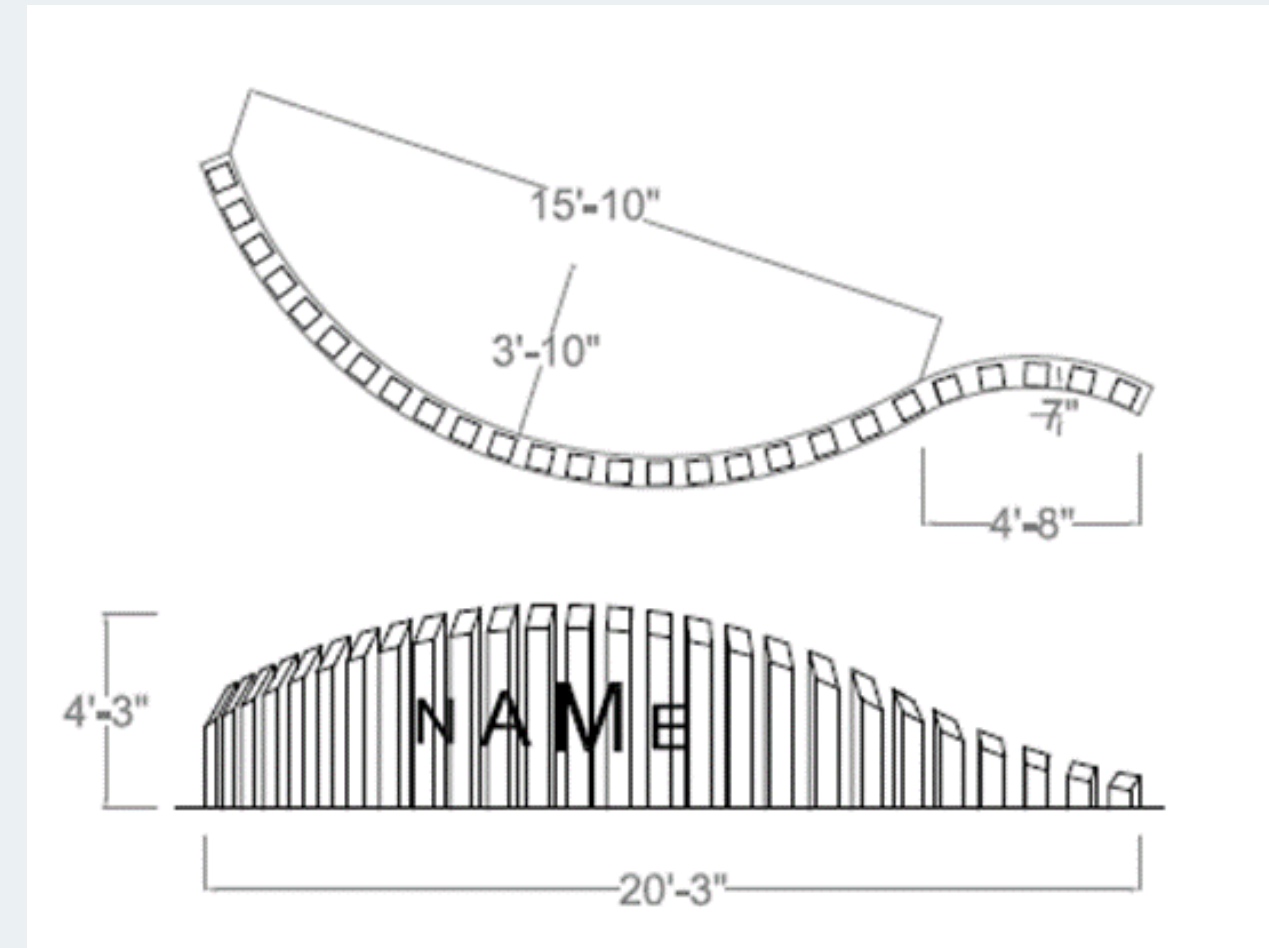
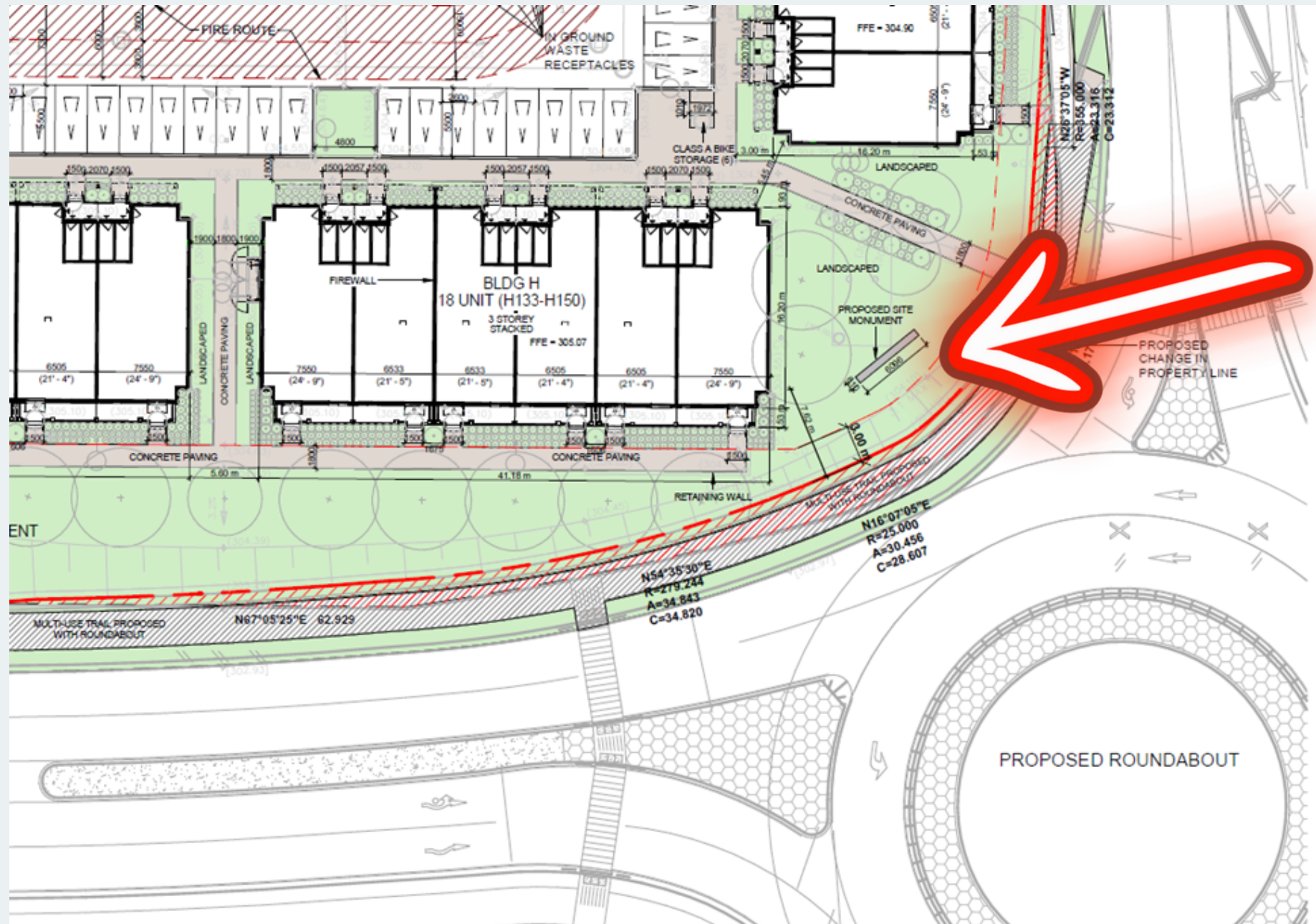

Salvaged barn materials



# On-site Commemoration Strategy

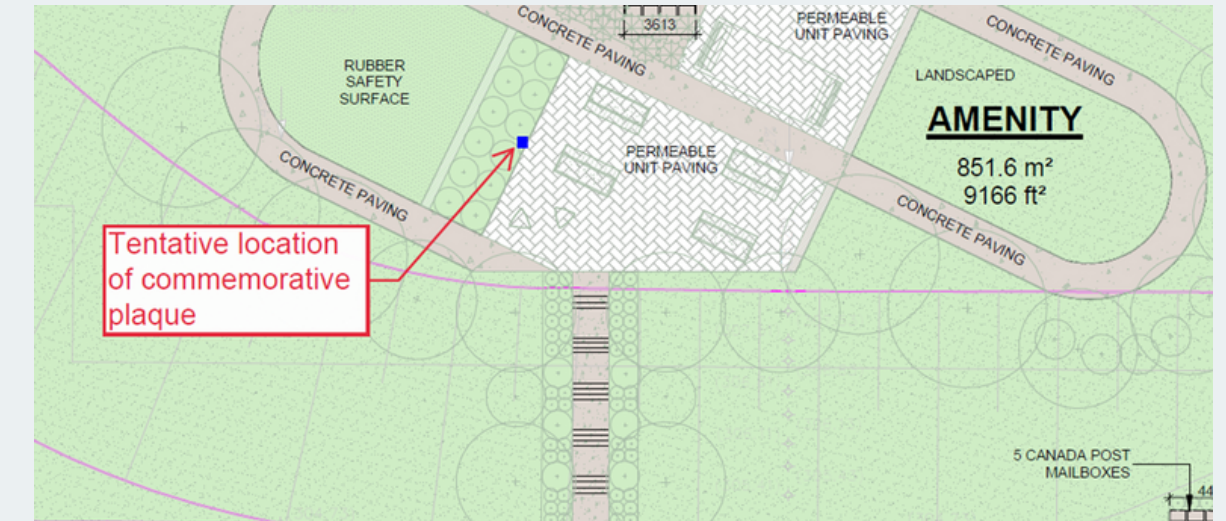
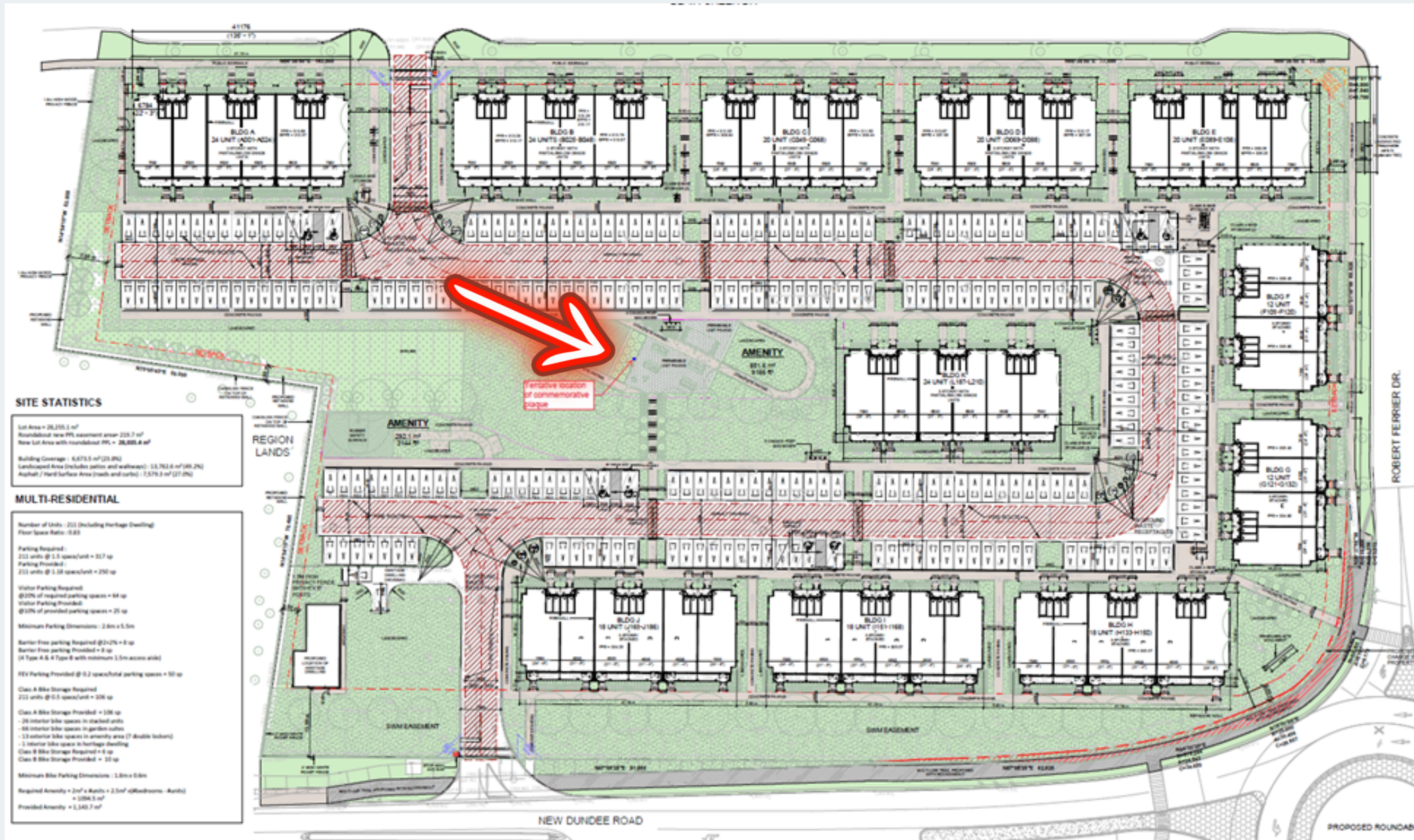

Plaque design & contents TBD

# Conclusions

- A Documentation & Salvage report has been submitted;
- Commemoration strategy submitted;
- Full site documentation & measured drawings.

# Recommendations

- Approval of Heritage Permit Application;
- Request MHAC recommend to council that **that property be removed from the heritage register as a listed property following the passing of the designation By-law.**

# Next Steps

- Submission of additional information to staff related to documentation, salvage, commemoration, etc.;
- Approval of Heritage Permit Application for alterations to dwelling in the near future.





QUESTIONS?